

The advantages of a fully integrated data tuner module for current and next generation cable modem designs

by Dave Donovan BSEE, MBA



Dave Donovan is Director of Marketing for Cable & Broadcast Products of ANADIGICS, Inc. He was formerly Director of Technical Marketing for Mitel Semiconductor & GEC Plessey Semiconductor for RF wireless, cable, and networking products. Field Applications Manager for Harris Semiconductor. Product Engineer for Analogue Devices. Dave has 20 years in the Semiconductor Industry.

Consumers making the switch from a traditionally slow analogue dial up modem service to a high-speed digital modem are driving the explosive growth for high-speed cable modems. A critical component of the cable modem is the data tuner...a physical layer interface device between the coaxial cable TV infrastructure and broadband data demodulator portion of a digital modem. ANADIGICS has developed a compelling new low cost double conversion tuner IC that replaces the traditional single conversion tuner and requires no external components.

While facing increased time to market pressure in a fast-paced market, cable modem designers must select from numerous data tuner options to complete their designs. A highly integrated tuner that minimises design and manufacturing time while providing the performance and price points required by the demanding consumer market can be an attractive solution that significantly reduces time to market and budget pressures facing today's designers.

Throughout the years, tuners have improved in integration, somewhat reducing the need for RF engineering expertise when designing a cable modem. Until recently, however, even the most highly integrated tuners required the use of 30 to 50 off-chip passive and filter components. This still entailed significant design efforts on the part of cable modem manufacturers, as well as reliability issues, higher costs, additional inventory, longer manufacturing times, and demanding board design layout. What was needed was a highly integrated, small-footprint, one-chip solution that required no external components.

The AIT 1000 PicoTuner™ is a solution well suited to satisfy the needs of today's designers (Figure 1) of cable modems and cable television (CATV) data tuners. Requiring no additional components in order to implement a complete RF tuner front end, the single-package device integrates an upconverter, down-

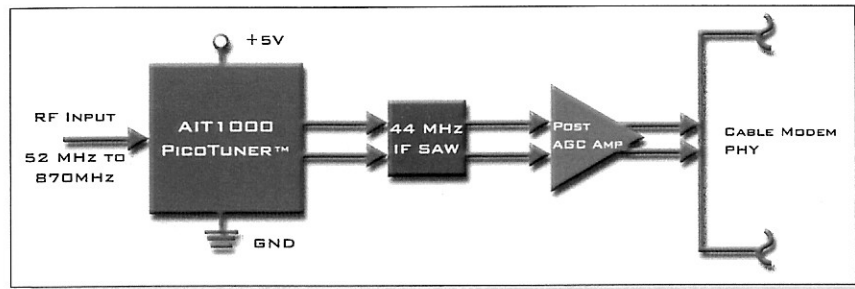

Figure 2: A block diagram of the PicoTuner™ in a cable modem application

converter, dual synthesiser, surface-acoustic-wave (SAW) filter, varactor, DC-to-DC converter, an input filter, tuning circuitry, and all of the required passive functions in a single 22 x 22mm multi-chip module (MCM) package. Manufactured using Gallium Arsenide (GaAs) and silicon CMOS technologies, the tuner enables DOCSIS compliant performance.

Tuner Choices

Essentially, a data tuner is a physical layer (PHY) device that connects the coaxial cable infrastructure (RF input) with the broadband data demodulation portion of a modem (Figure 2). The modem can be installed in a cable modem desktop box, a personal computer (PC) card, a digital or advanced analogue set top box (STB), or in a home gateway box, as in Voice over Internet Protocol (VoIP) for cable telephony.

In any of these applications, the tuner is responsible for selecting one of the 135

coaxial cable channels which are spaced 6-MHz apart (8MHz apart in Europe) in the receive stream, and rejecting the remaining non-requested channels. Tuners serving this function can be implemented in single-conversion (SC) or double-conversion (DC) designs.

An early tuning solution, SC tuners are large, manually tuned modules that use a tracking filter to select a channel. Because this type of filtering requires manual tuning during manufacturing, they are typically more expensive than integrated circuit double-conversion designs. Typically SC tuners are comprised of a few ICs and hundreds of discrete components housed in a shielded metal "can".

Double conversion tuners integrate an upconverter and downconverter function in order to multiply all of the channels entering the modem by a known frequency, typically 1.1 to 1.3GHz. This allows the tuners to use a SAW filter, which is by nature much more selective than a tracking filter, to precisely tune to a single cable channel. Channel selection is accomplished with an integrated dual synthesiser under the control of a DSP broadband demodulator chip.

While the double conversion tuner offers more precision, many early designs required additional external components such as a varactor to tune the upconverter from 52 to 870 MHz, a +30 VDC supply for controlling the tuning range, input filters and loop filters. This added to component count and increased the total solution cost.

Efforts to integrate these and other

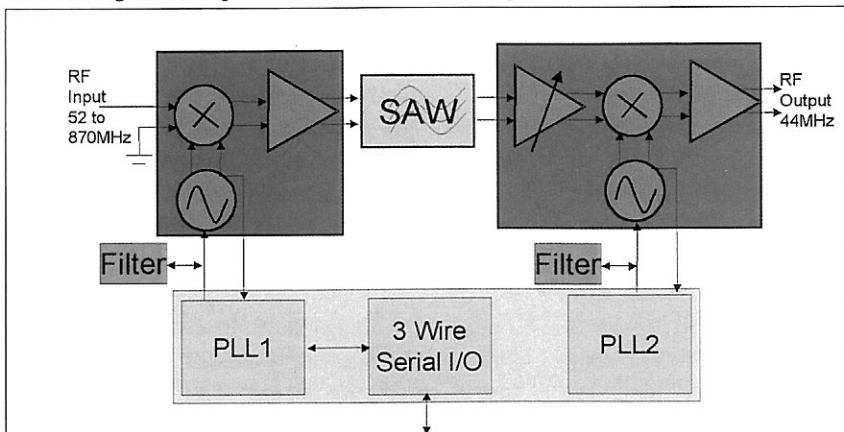

Figure 1 : A detailed block diagram of the AIT1000M6 PicoTuner™

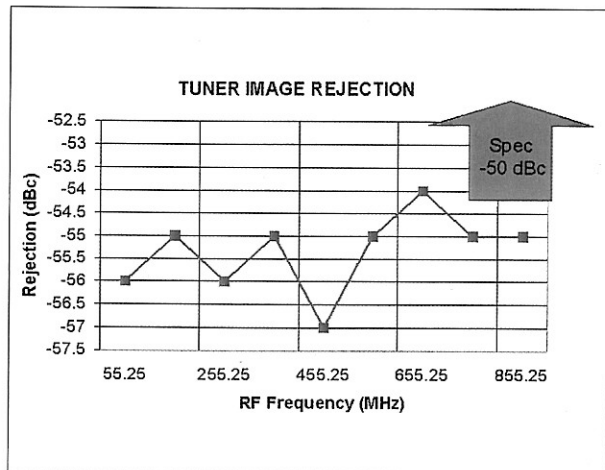

Figure 3 : Tuner Image Rejection for the PicoTuner™ across 55.25 to 855.25MHz.

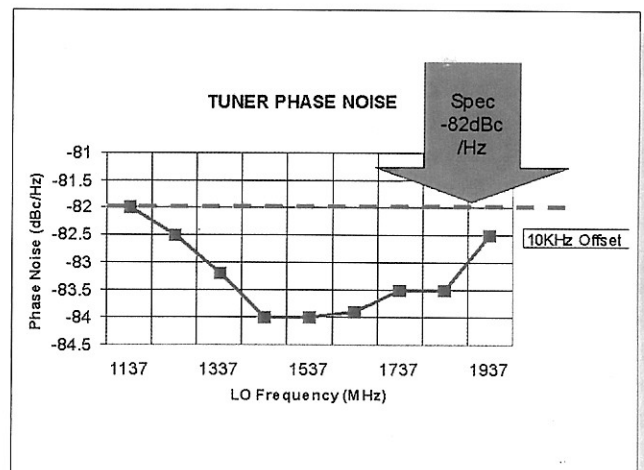

Figure 4 : Tuner Phase Noise for the PicoTuner™ across LO frequencies of 1137 to 1937MHz.

external passive components led to the PicoTuner™ double-conversion solution, which offers the benefits of precision without the need for external passives, and in a lower-cost solution than other IC-based or SC tuners.

Performance

While cost, size, and ease of use are all important in today's cable modem market, the end product is ultimately judged by its overall performance. In the case of the cable modem, this is its ability to precisely tune into one channel by rejecting the signals from the remaining channels without introducing a noticeable amount of noise from its own circuitry. Some of the major specifications of concern, then, in a cable-modem tuner include image rejection, phase noise, and noise figure.

Image rejection is a measure of how well a tuner isolates a desired channel. One of the reasons double-conversion tuners use SAW filters is that they enable good image rejection. The PicoTuner™ for instance, features image rejection of better than -50dBc (Figure 3).

Noise is another concern for tuner performance, including phase noise—the amount added by the tuner's local oscillators (LOs)—and the noise figure, or total noise introduced to the receive chain by the tuner. The AIT1000 tuner features typical phase noise of -85dBc/Hz at 10-

kHz offset from the carrier (Figure 4), and a typical noise figure of 8.5 dB. These specifications can be attributed to design approaches that minimize cross coupling of the RF signals and the interactions between the LOs in the up and down converters. This result was achieved by taking advantage of IC and tuner intellectual property as well as a low-noise GaAs process.

Next Generation Considerations

One of the latest concerns for the cable market is a general reduction in power consumption throughout the system. This has been brought about by inroads into cable telephony, which requires power backup schemes in order to guarantee phone service even when there is an electrical power outage, or so-called "lifeline power." The first-generation PicoTuner™ is a +5-VDC design with a typical supply current of 350mA. The basic tuner platform will also be developed in a +3-VDC design that features power consumption below 750mW, making it well suited for VoIP-based cable telephony in home gateways. Because many of these home gateways will be mounted outside of the residence, it is also important for the tuner to operate in an industrial temperature range of -40 to $+85^\circ\text{C}$.

CONCLUSION

Increasing consumer demand for bandwidth and cable services is causing cable product designers to improve or stretch the performance capabilities of its equipment in much shorter design cycles. As a result, the product lifetime of cable modems is shrinking, and the requirements for its internal components continue to increase. And, all of this rapid design is taking place within strict cost budgets. It is important, then, to select a tuner solution that offers an easy upgrade path, such as a single chip module with minimal external components. When the manufacturer has committed to a module platform, such as the PicoTuner™, future upgrades can be as simple as replacing the device with the next-generation design, which avoids costly and time-consuming redesign.

As cable modems continue to penetrate the consumer market around the world, it is important to select a data tuner that enables quick design time, easy upgrades, and performance that meets or exceeds global standards. And, as cable modems become integrated into more products, such as PC cards, a small form-factor solution is also beneficial. Selecting a fully integrated tuner enables designers to meet all of these needs, with the added benefit of a low cost solution.